

T How To Make A Basic Skirt k

With just a few simple measurements

A Practice Guide

How To Make A Simple Skirt Pattern

With just a few simple measurements!

Copyright © 1994 2000 by Tammie Bowser Joyner. All rights reserved. No part of this book may be reproduced in any form or by any electronic or mechanical means including informational storage and retrieval systems without permission in writing from the publisher. Requests for permissions should be addressed in writing to: Ez-fit Patterns P.O. box 555, South Pasadena, California 91031-0555

Printed in the United States of America

Congratulations! You have just taken your first step towards making simple skirts that fit. I am really excited about this opportunity to present it to you. As a home sewer myself for most of my life, I've always had the problem of the store bought commercial patterns not fitting. I was frustrated and I also felt ripped off. This frustration gave me the desire to find out the "secret" combination to making patterns that fit.

After two years of schooling and ten years of working in the fashion business as a professional patternmaker, I found out the "secret" combination! It is so easy that I want to pass it on to you, so that you won't have to suffer any longer.

The real "secret" is, most clothing manufacturing companies, and pattern making companies don't make their clothes or patterns to fit regular every day people. The fit models they use are most often from modeling agencies and they are the ideal woman's figure, not the figure of the average American woman!

If you follow my easy instructions, you can have a skirt pattern that fits you, or any one else you choose in as little as two hours! You will be amazed at how easy it is!

First of all, I'd like to explain a few terms that I will be using through out the book.

CROSSMARK

A short line used to indicate a matching point, stitching point, or where a seam joins together.

DART UNDERLAY

This is the inside portion of the "V" shape of a dart.

NOTCH or NOTCHES

An indentation on a finished pattern that indicates darts, seam allowances, and matching seams.

PUNCH HOLE

A mark that indicates the point of the "V" shape of a dart.

O.K., now that our definitions are clear, lets move on to what tools you will need.

1)The first thing you will need is a regular no. 2 pencil, and an eraser. You can also use a mechanical pencil if you are more comfortable with them.

2) The second thing you will need is paper. Big paper. The best paper to use is dotted pattern paper that has small dots all over it in a 1x1 inch grid. This grid makes it easy to draw perfectly square lines, and it's also easy to measure. You may be able to order this kind of pattern paper from your local fabric store. Another option is your local newspaper. If you ask, they are usually willing to sell you some clean paper on a roll (this paper doesn't have the 1x1 inch grid). You can also use butcher paper.

3) The third thing you will need is a soft tape measure. You probably already have one, but I don't want to take it for granted that you do.

The fourth thing you will need are rulers. I recommend a ruler that is clear and has a hip curve on one side of it. This ruler is called "Fashion Ruler for easy altering no. 670" and is made by Fashionetics Inc. You can find this at your local fabric store. Or you can order it for \$7.50 at: Fashionetics Inc., P.O. Box 146, Armonk, N.Y. 10504. I also recommend a ruler called an L-square. It is good for making perfectly square lines. It is especially useful if you are using paper that doesn't have the 1x1 inch grid. Square lines

are very important in making your skirt correctly. You can find an L-square at any art , hardware, or stationery store.

- 5) The fifth thing you will need is a large working space or table. You can probably use the same working space you usually use for your other projects.
- 6) The sixth thing you will need is a calculator, it's not a prerequisite, but it will make life easier.
- 7) The last thing you will need is about two hours of your time. It will be time well spent.

S

Skirt Book

Be sure to take great care in taking accurate measurements. These measurements are necessary to make your skirt fit you properly. So be sure to be honest, no one else is looking!

It is best to remove your shoes and to tie a string around your waist. The string around the waist is for ease in finding the waistline while measuring. Be sure the model doesn't look down while measuring because it will make the measurements inaccurate. If you are measuring yourself, to keep from looking down while measuring, it is helpful to stand in front of a full length mirror.

YOUR CHART

R. Hip measurement plus 2" _____

B. Divide hip measurement (R) in half, then, add 1/4" Put your results in this space for later use
Front hip _____

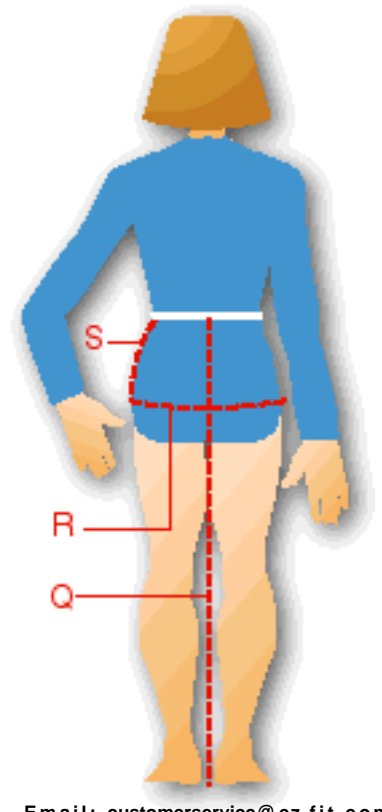

- C.** Divide hip measurement (A) in half, then, subtract 1/4" Put your results in this space for later use

Back hip _____

- L.** Waist Measurement plus 1 1/2" _____

- D.** Divide waist measurement (L) in half, then, add 1/4" Put your results in this space for later use

Front waist _____

- E.** Divide waist measurement (L) in half, then, subtract 1/4" Put your results in this space for later use

Back waist _____

- S.** Hip Depth, measure from your waist down to your widest hip measurement. On some people it is 7" down from the waist and on others it could be 9" _____

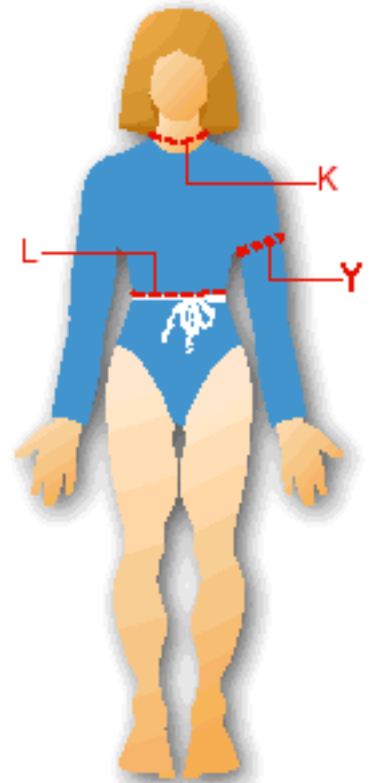
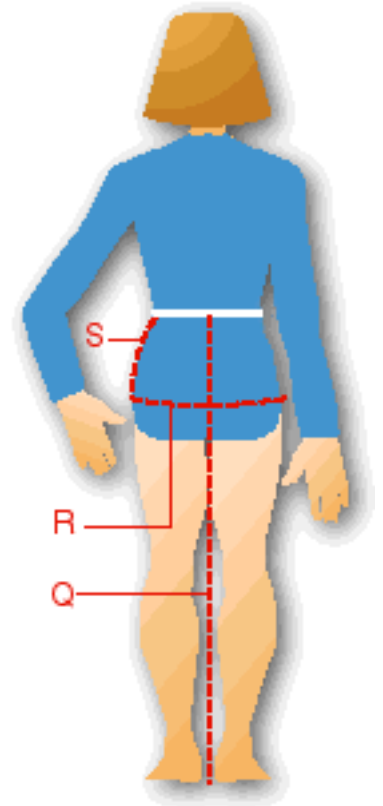

1. Cut your paper about 45" long and a few inches more than the width of your total hip measurement.
2. Draw a straight line the length of measurement (S) Hip depth, on the right side of the page as shown below. Use a crossmark to mark the top (front waist).
3. Make a squared line across the page starting from the bottom of the hip depth. This line should be half of your hip measurement (R). At the end of this line, make another line straight up as shown.
4. Now make a line for the side seam, using (C) , and (B) front hip measurement to find the correct placement.

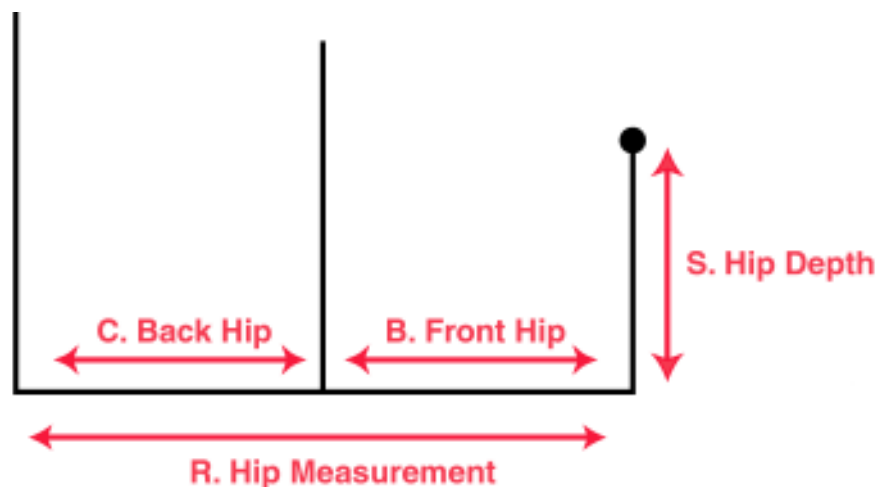

5. Now make a straight line across the top of the drawing, starting at the top of the center front line as shown.

6. On the side seam, make a line 1/2" up from the new waist line you just drew in step 5. Now on that line, mark out 3/4" in each direction from the side seam. These marks are the top of your side seams.

7. With a curved ruler, make two lines as shown blending the tops of the side seams to the hip at the side seam.

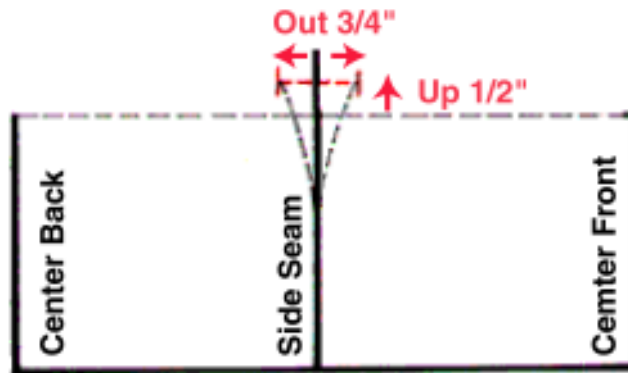

8. Starting from the top of the center back waistline, Measure down 3/8", then mark this as your new top of center back waist. Connect your center front to the side seam, and the center back to the side seam as shown.

9. Measure your front waist, then subtract the (D) Front waist from the measurement chart. The difference will tell you how wide your front darts will be. Divide this measurement in half if you want two darts.

10. Measure your back waist, then subtract the (E) Back waist from the measurement chart. The difference will tell you how wide your back darts will be. Divide this measurement in half if you want two darts.

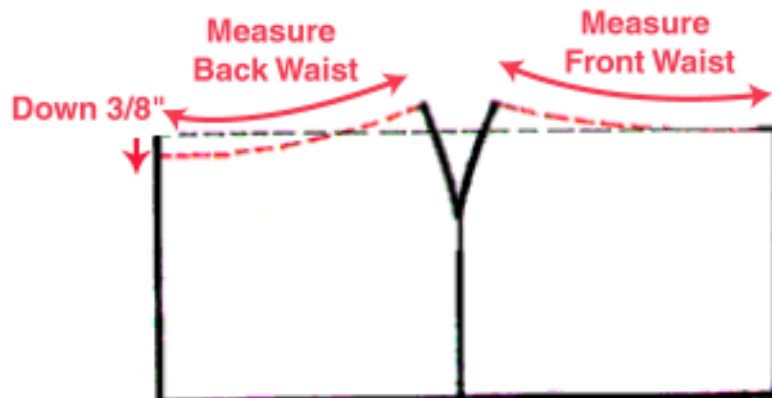

11. To make your darts, use the diagram below to figure out the placement

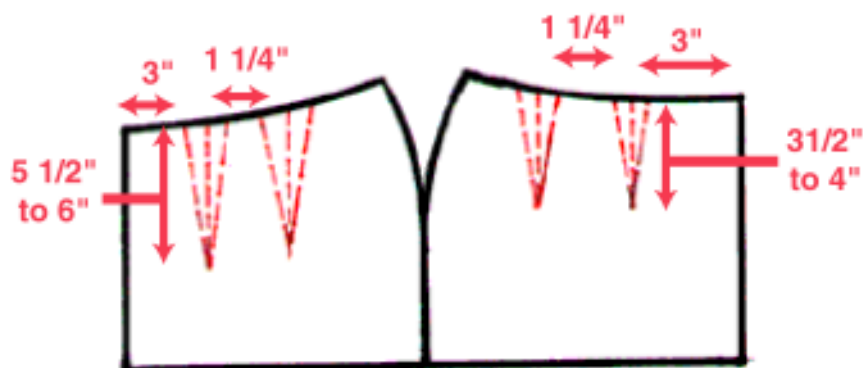

12. Lengthen your skirt to your desired length. You can make your skirt long or short.

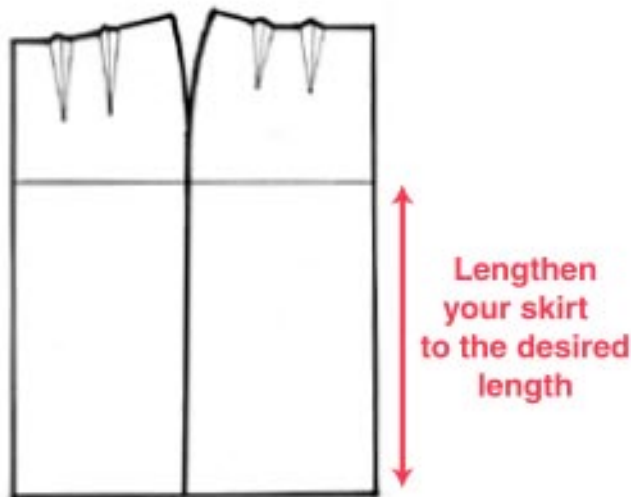

12. Now to finish your skirt pattern, just cut it apart, and add your hems and seam allowances. Do not forget to make a waistband and a back vent.

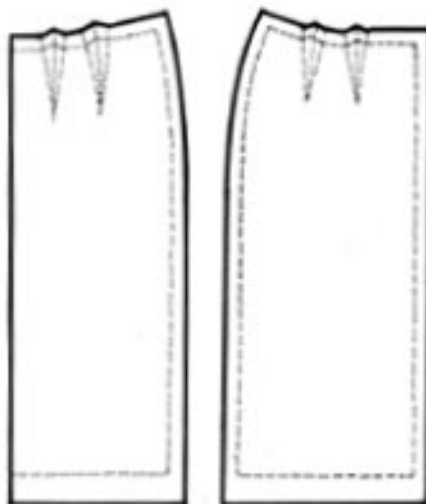

Add your seam allowances as shown

SEWING INSTRUCTIONS



Purchasing Fabric

- ❖ Remember to buy more fabric than we recommend if you are using stripes, plaids, or fabric with a one way nap (i.e.: corduroy, velvet, terry cloth).
- ❖ Since each pattern is custom made to order, we can only give approximate estimations of fabric requirements.

Use the “Size Profile” chart to determine which size to use, when determining fabric requirements for your pattern:

Jackets - use the bust size profile.

Skirts - use the waist or hip size profile (which ever is largest).

Dresses and Jumpsuits - use bust, waist, or hip size profile (which ever is largest).

Size Profile

| | Bust | Waist | Hips |
|----------|-------------|--------------|-------------|
| 1 | 30"-33" | 23"-25" | 32"-35" |
| 2 | 34"-37" | 26"-29" | 36"-39" |
| 3 | 38"-43" | 30"-34" | 40"-44" |
| 4 | 44"-49" | 35"-41" | 45"-50" |
| 5 | 50"-55" | 42"-47" | 51"-56" |
| 6 | 56"-60" | 48"-53" | 57"-61" |

Estimate of Fabric to Buy***

| | 1 | 2 | 3 | 4 | 5 | 6 |
|-------------|--------------------|--------------------|--------------------|--------------------|--------------------|--------------------|
| 45" (115cm) | 1 3/4 yds (1.6) | 1 3/4 yds (1.6) | 1 7/8 yds (1.7) | 2 yds (1.9) | 2 1/4 yds (2.0) | 2 1/4 yds (2.0) |
| 60" (150cm) | 1 yds (1.0) | 1 yds (1.0) | 1 1/8 yds (1.0) | 1 1/4 yds (1.1) | 1 1/2 yds (1.4) | 1 1/2 yds (1.4) |

***We recommend that you layout your pattern pieces to determine your exact yardage requirements.

SEWING INSTRUCTIONS

1 Take the two back skirt pieces and overlock the center back and the edge of the back vent.

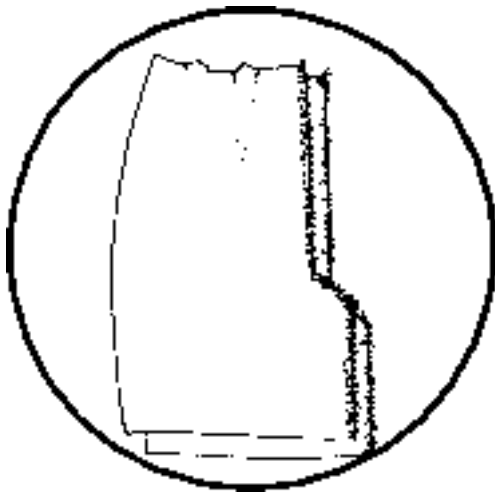

2 Place the back skirt pieces right sides together. Then stitch the center back closed from the zipper notch down to the back vent as shown. Overlock the center back seam.

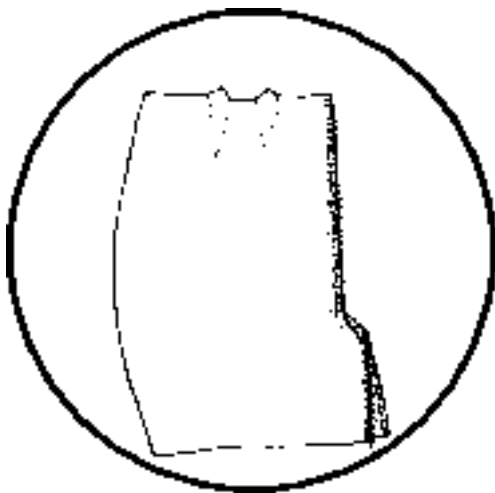

3 To apply the zipper, first fold and press the right side of the center back seam open 1/4" from the notch up to the top as shown.

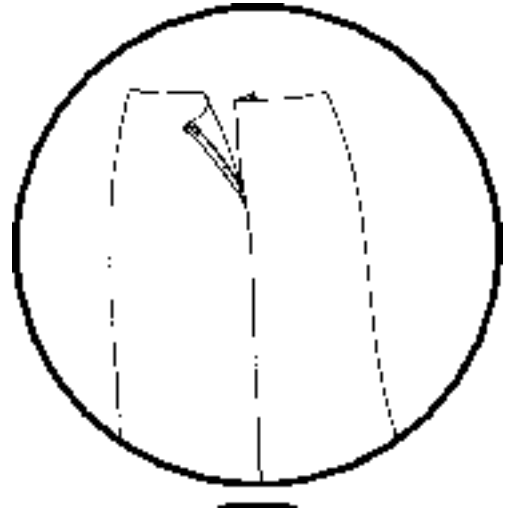

4 Pin the zipper in place as shown with the teeth "beginning 1/2" below the top edge of the skirt. Topstitch the skirt edge to the zipper 1/8" away from the teeth using a zipper foot on your machine.

To attach the left side of the zipper, fold and press the left side of the center back seam open 3/4" as shown.

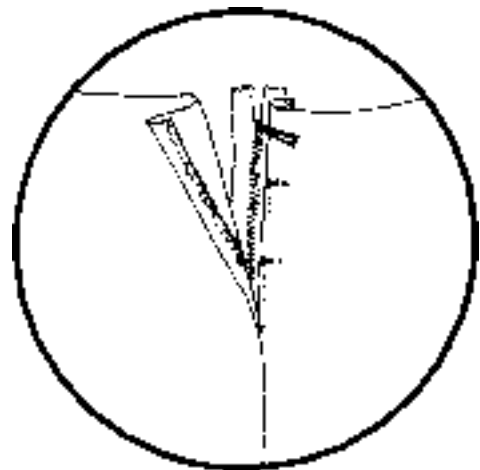

SEWING INSTRUCTIONS

5 Now pin the folded edge of the left side of the skirt 1/4" past the teeth to cover the zipper, the seam, and the stitching.

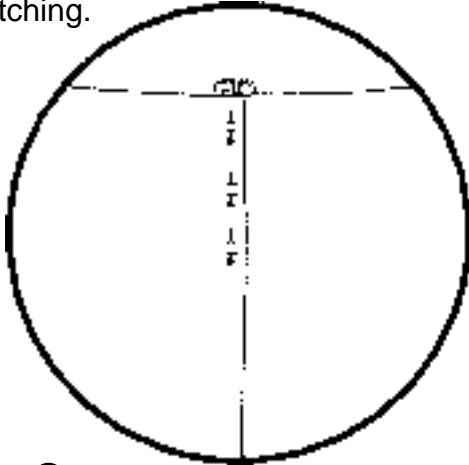

6 Turn the back skirt to the inside and stitch a straight line through the zipper tape and yoke, 1/8" away from the zipper teeth. Start from the top of the yoke, and stitch down to the bottom of the zipper.

When you reach the bottom of the zipper (make sure you are past the metal zipper stop) leave the needle in the down position. Raise the presser foot and turn the yoke towards the center back seam. Continue to stitch to the center back. Back tack. Remove pins

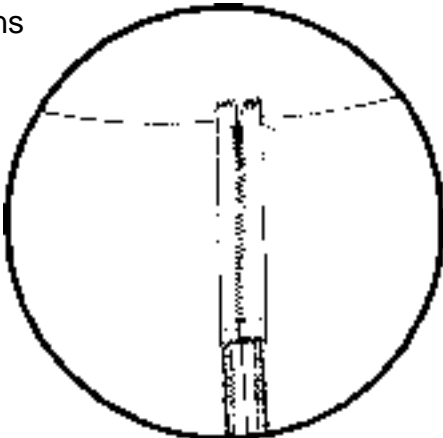

7 Sew darts closed on front and back skirt. Press darts on the fronts towards the center front, and the back darts towards the center back.

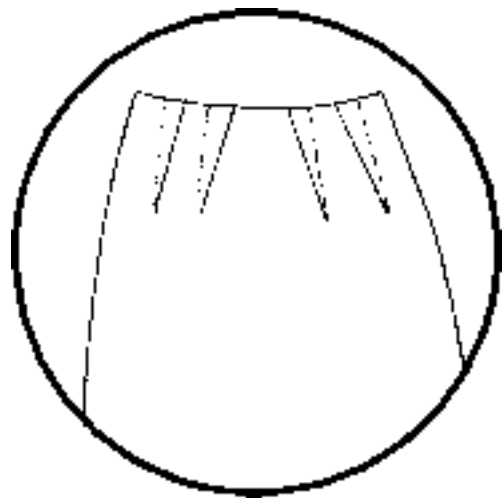
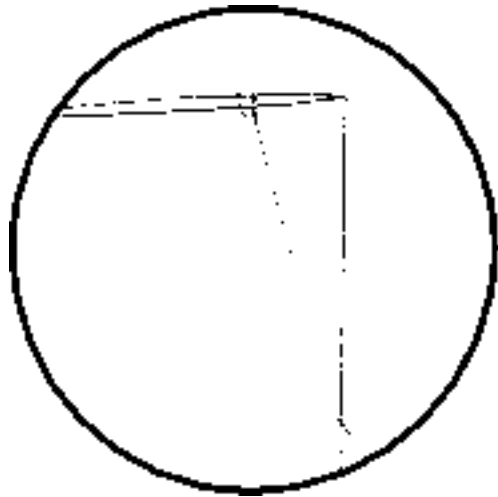

SEWING INSTRUCTIONS

8 To finish the back vent, fold the vent to the right side as shown. Press flat, and topstitch the top of the vent to keep the vent in place.

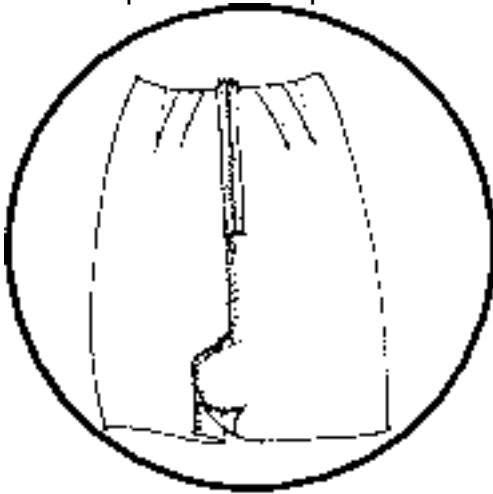

9 Place the front skirt and the back skirt right sides together. Stitch side seams closed and overlock.

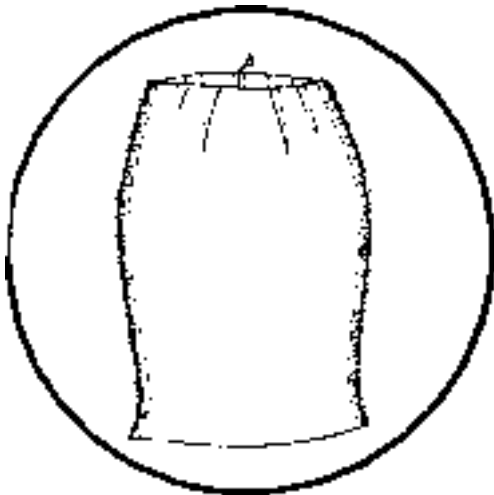

10 Now overlock the bottom of the skirt. Fold the hem up 1-1/4" and iron flat. You can now slip stitch the hem by hand, or topstitch the hem by machine.

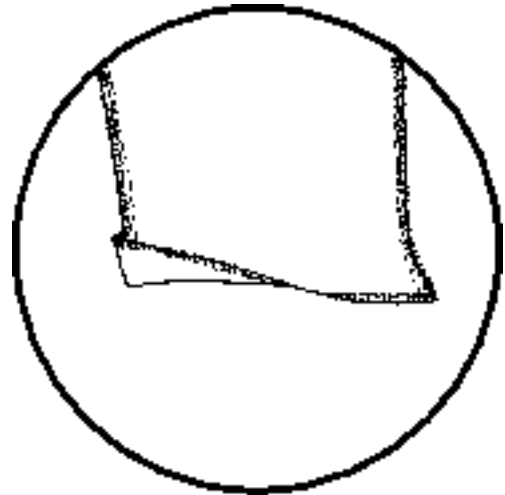

11 Apply the interfacing to the waistband.

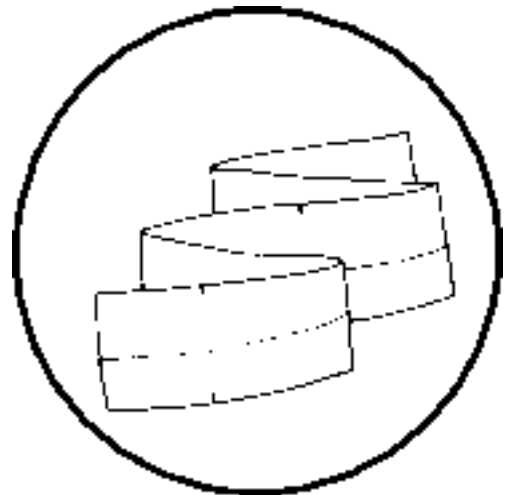

SEWING INSTRUCTIONS

12 Fold the waistband in half the long way, and stitch the short ends closed. As shown.

Turn the waistband right side out. Pin the waistband to the waist of the skirt (with right sides together). Match the waistband to the skirt leaving a 1" hangover on the back left side of the skirt as shown. Stitch the waistband to the skirt.

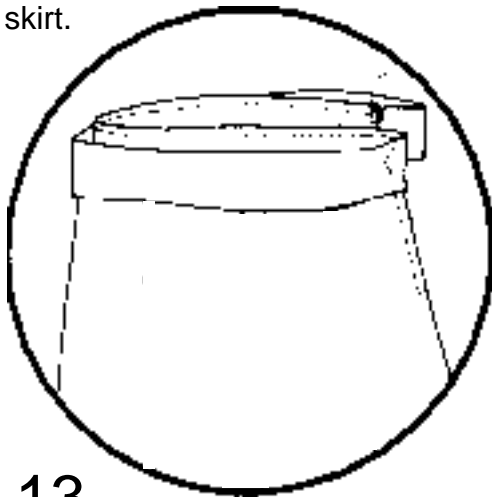

13 Pull the waistband up, folding the seam allowance up into the waistband. Fold the inside of the waistband 1/2", and pin the waistband in place (covering the waist seam).

Stitching on the outside of the skirt, 1/8" edge stitch the waistband along the bottom, as shown. Be sure to catch the bottom edge of inside waistband. Remove pins.

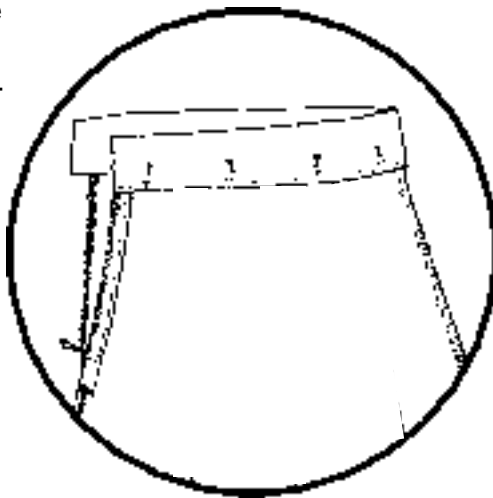

14 Apply your button and button hole.

